

<b>SERVICE BULLETIN</b>		
<b>To:</b>	<b>All Dealers</b>	<b>Reference</b> <b>SB-17-0298</b>  <b>Issued:</b> <b>26 February 2009</b>
<b>For the attention of:</b>	<b>Service Manager/After Sales Manager</b>	
<b>Please copy to:</b>	<b>The Dealer Principal</b> <b>The Warranty Administrator</b> <b>Aston Martin Technician(s)</b> <b>The Parts Manager</b>	
<b>Model:</b>	<b>DBS, DB9, V8 and V12 Vantage</b>	
<b>VIN Range:</b>	<b>All</b>	<b>Page 1 of 5</b>
<b>Subject:</b>	<b>Headlamp Drying Out Procedure</b>	

### Reason for this Service Bulletin

The headlamps of DBS, DB9, V8 and V12 Vantage models can get condensation on the inside surface of the lens. If a customer complains that their vehicle has condensation in a headlamp, do the applicable procedure that follows to remove the condensation.

### Workshop Procedures

#### DBS and DB9 Vehicles

1. Turn the steering to get access to the headlamp access panel for the correct headlamp.
2. Lift the vehicle and make it safe.
3. Release the quarter-turn fastener and remove the headlamp access panel (refer to Figure 1).



**Figure 1**

4. Remove the dip-beam bulb cover from the headlamp.
5. Install a battery vent tube (part number 1R12-372635-AA) (1) into the headlamp in the position shown in Figure 2 and Figure 3.



Figure 2

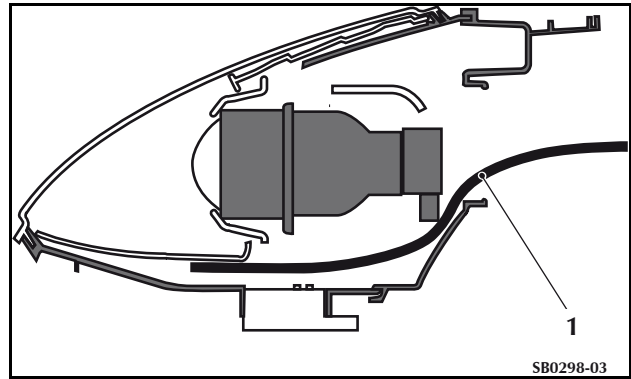

Figure 3

6. Attach an airline that has dry air, without oil to the battery vent tube (refer to Figure 4)

**CAUTION: MAKE SURE THAT THE AIRLINE PRESSURE IS 2 BAR OR LESS. IF YOU DO NOT, DAMAGE TO THE HEADLAMP CAN OCCUR.**



Figure 4

7. Make sure that the opposite end of the vent tube has not moved inside the headlamp. If necessary, adjust its position.
8. Blow air through the headlamp until you can see no condensation remaining on the lens.
9. Let the air flow for 20 minutes more.
10. Remove the vent tube from the headlamp then do steps 11 to 13 that follow quickly before more moisture can get into the headlamp.
11. Remove the cover for the main-beam bulb.
12. Install two silica gel bags into the headlamp at the positions shown in Figure 5.

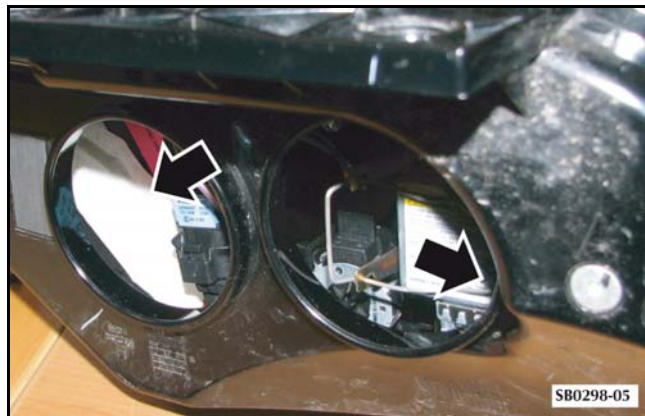

Figure 5

13. Install the two bulb covers. Make sure that the covers are fully installed correctly.

14. Install the headlamp access panel and turn the quarter turn fastener to attach it.
15. Lower the vehicle.
16. Adjust the steering to the straight forward position.

### V8 and V12 Vantage Vehicles

1. Turn the steering to get access to the headlamp access panel for the correct headlamp.
2. Lift the vehicle and make it safe.
3. Release the quarter-turn fastener and remove the headlamp access panel.
4. Remove the two screws (1) that attach the bulb cover (2) to the headlamp (refer to Figure 6).

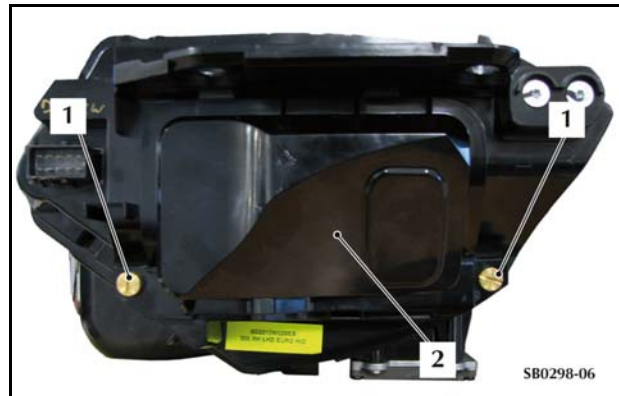

Figure 6

5. Remove the bulb cover from the headlamp.
6. Install a battery vent tube (1) into the headlamp in the position shown in Figure 7 and Figure 8.

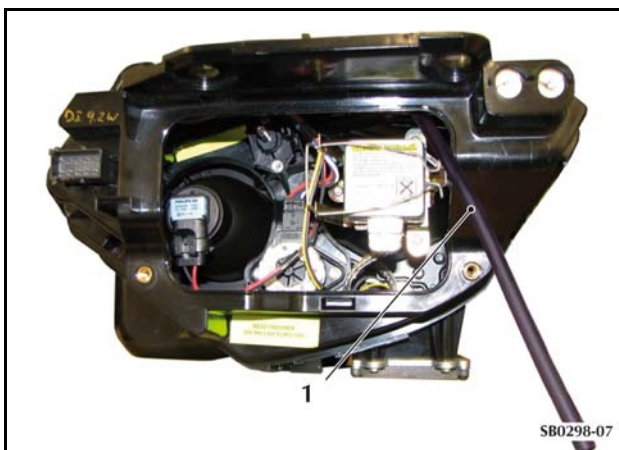

Figure 7



Figure 8

7. Attach an airline that has dry air, without oil to the battery vent tube (refer to Figure 9)

**CAUTION: MAKE SURE THAT THE AIRLINE PRESSURE IS 2 BAR OR LESS. IF YOU DO NOT, DAMAGE TO THE HEADLAMP CAN OCCUR.**



Figure 9

8. Blow air through the headlamp until you can see no condensation on the lens.
9. Let the air flow for 20 minutes more.
10. Remove the vent tube from the headlamp then do steps 11 and 12 that follow quickly before more moisture can get into the headlamp.
11. Install two silica gel bags into the headlamp (refer to Figure 10 – right headlamp shown).

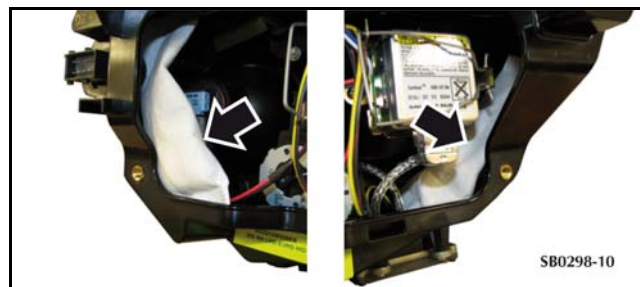

Figure 10

12. Install the bulb cover.
13. Install and tighten the two screws that attach the bulb cover.
14. Install the headlamp access panel and turn the quarter turn fastener to attach it.
15. Lower the vehicle.
16. Adjust the steering to the centre.

**Part Data**

Description	Part Number	Quantity
25g Silica Gel Bag (2 each pack)	9G43-37-11095-PK	2 per headlamp
Battery Vent Tube	1R12-372635-AA	1

**Warranty Data****DBS and DB9, Coupe and Volante**

Description	Time Allowed	Labour Code
Headlamp Condensation Drying Procedure – The two sides	0.9 hrs.	17.01.BG
Headlamp Condensation Drying Procedure – One Side	0.45 hrs.	17.01.BH

**Vantage Coupe and Roadster**

Description	Time Allowed	Labour Code
Headlamp Condensation Drying Procedure – The two sides.	1.0 hrs.	17.01.BG
Headlamp Condensation Drying Procedure – One Side	0.5 hrs.	17.01.BH

If you have any queries related to this Service Bulletin, please contact: Aston Martin Technical Services on:  
+44 (0) 1926 644720 or facsimile: +44 (0) 1926 644733.  
E-mail: [amtech@astonmartin.com](mailto:amtech@astonmartin.com). Or contact your After Sales Manager.

The English version of this Service Bulletin is written in  
Simplified Technical English to ASD STE-100™.