



TheRock's – 997 Rear Bumper Cover Removal Guide

Helpful Tools:

Various Torx bits, Phillips Screwdriver

Torque values:

Wheel to car / hub	130 Nm (96 ft.lb.)
--------------------	--------------------

As always, this is how I did it and not suggesting you do it this way or any other specific way. Do so at your own risk and in any fashion you choose to do it. This guide is simply in the spirit of offering a method that worked for me.

Good luck!

1. **Jack up vehicle or place on lift and remove rear wheels** - Note: remember to break lug bolts before lifting. While it is not necessary to remove the wheels, it makes it much easier.



2. Remove Rear Wheel liners: Remove 5 Torx screws highlighted and pull wheel apron out. Note: There is one torx screw for the bumper cover straight up under the front edge of the bumper cover that you will see once the apron is removed.



3. **Remove Tail Lights:** One Phillips Screw just inside deck lid (and disconnect electrical plugs).

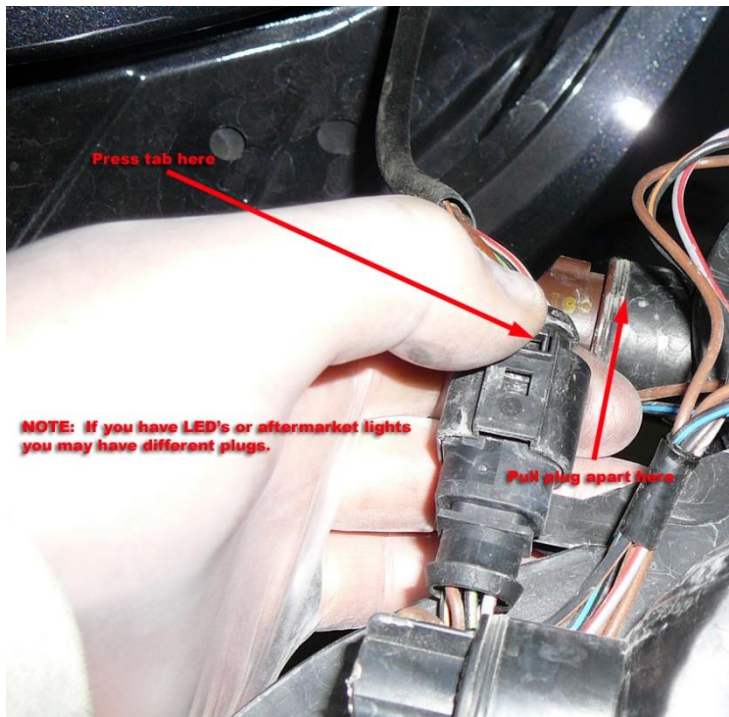
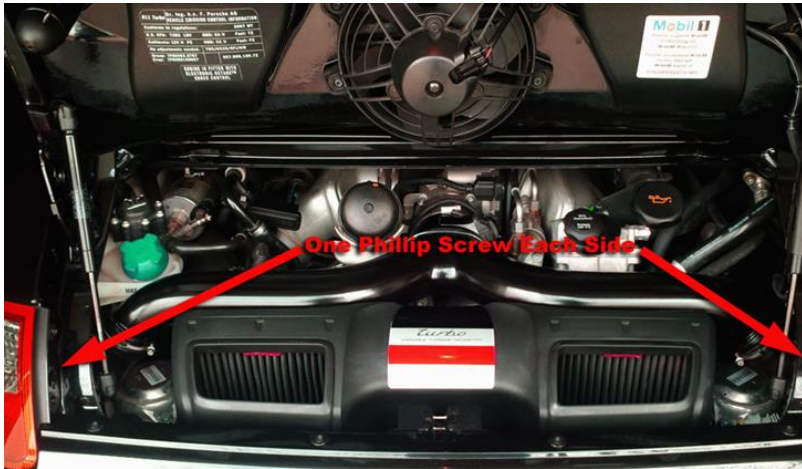

4. Unscrew expanding pin -1- and unclip the expanding clip -2- (Pic 1). And unscrew fastening screws -1- at the sides of the rear apron -2- (Pic 2).

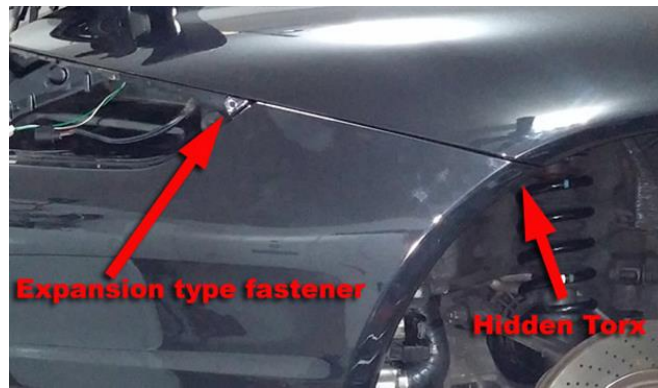
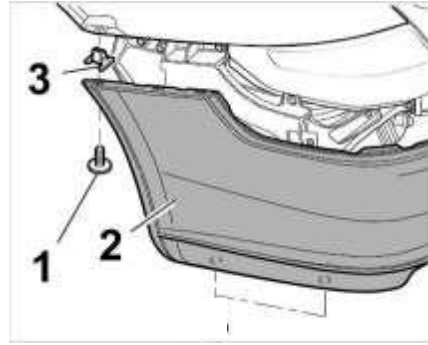
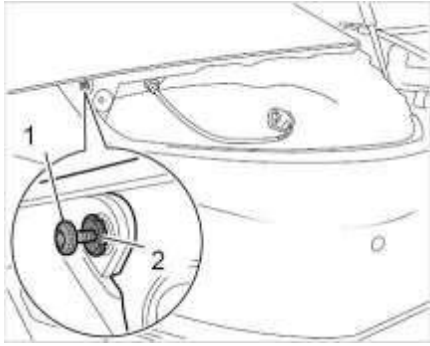

5. Unscrew fastening (torx) screws at the top and bottom of the rear apron – Then pull cover straight out

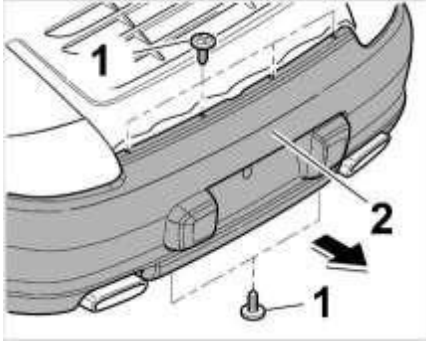

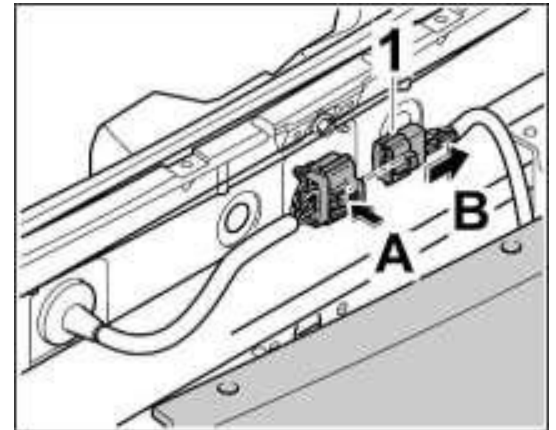

To Re-Install...All of the above in Reverse.....Enjoy...

Take your time...and put it all back together...when done...you should have no extra parts if done right 😊

